



# MONITORED DOOR STATUS SLIMLINE MAGNETIC LOCK (600LB / 280KG)

**MAGNETIC LOCK**

Fire tested range of maglocks and brackets from a market leader in access control.

**FIRE TESTED** to BSEN1634-1-2014  
(30, 60, 90 & 120 min timber door-sets)



**ML600-MDS**

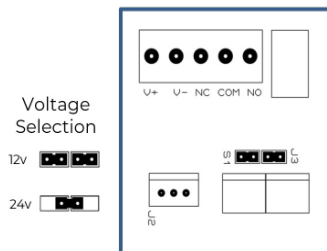
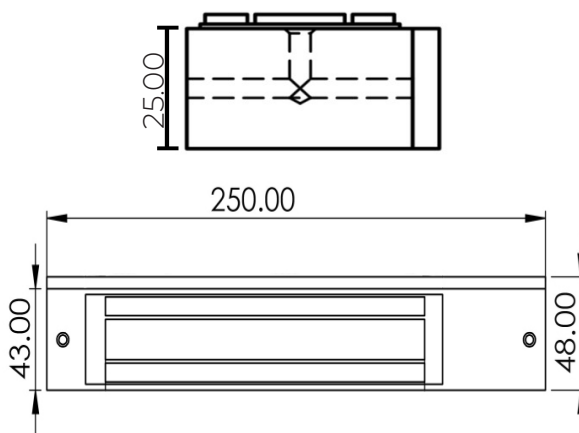

SPECIFICATION	FEATURES	OTHER PRODUCTS
---------------	----------	----------------

**ML600-MDS**

- Aluminium housing
- Dual voltage 12/24 VDC @ 480/240mA
- 280kgs (600lb) holding force
- Built in surge protection
- Surface mount
- Fail safe operation (power to lock)
- +/- 15% voltage tolerance
- 10° to +50° operating temperature
- Push off release pin on armature

- Monitored (Lock Monitoring)
- Voltage free relay contacts
- Door Status Monitoring

(Lock monitoring checks maglock is reporting itself as locked, Door status monitoring has a contact that works independently from Maglock, and shows if the door is open or closed)

**ML600-MDS**

- Fire rated (30, 60, 90 & 120 min timber door set)
- Slimline mini magnet
- Clean and compact design
- No residual magnetism
- Status LED indication on ML600-MDS

Suitable Brackets/Housings:

- BK600ZL (ZL bracket)
- BK600L (L Bracket)
- BK600-F-L/AB (Architectural FL)
- AB600ZL-DC (Architectural ZL)
- AB600CL (Architectural L)
- ADJ600-L (Highly adjustable L)
- AH600 (Required for Fire Doors)
- BK600U (Glass door bracket)
- GD600ZL (Glass Door ZL)



**DIMENSIONS**

**ML600-MDS**

- 250x43x25 (mm) Maglock
- 180x38x13 (mm) Armature
- 1.97kg Boxed
- 1.13kg Unboxed

**CONTENTS**

**ML600-MDS**

- Slimline mini magnet (600lb)
- Armature plate
- 600GB fixing kit
- Instructions
- Armature fixing template

